

**PLAN VIEW**

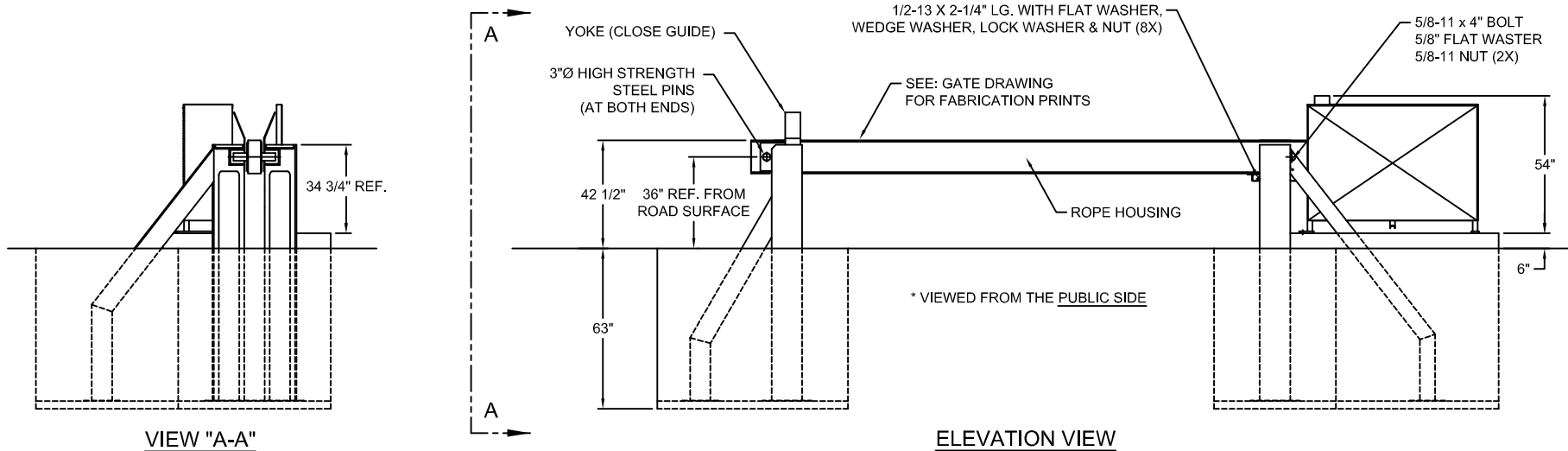

**ELEVATION VIEW**

**VIEW "A-A"**

Signature: \_\_\_\_\_

Date: \_\_\_\_\_

**DO NOT SCALE**

Rev.:	Description:	Date:

**NOTICE**  
 THE INFORMATION CONTAINED ON THIS DOCUMENT IS CONFIDENTIAL. ANY DISSEMINATION, UNAPPROVED DISCLOSURE OR COPYING OF THIS INFORMATION IS STRICTLY PROHIBITED.  
 UNLESS OTHERWISE SPECIFIED DIMENSIONS ARE IN INCHES ANGLES ± 1°  
 X/X ± 1/32, .XX ± .01, .XXX ± .005

Date: 12/16/08  
 Dr. By: MKS  
 Ckd. By: .  
 Dwg.: .  
 Title: K12 GATER - Crash Barrier Gate - L.H.

