

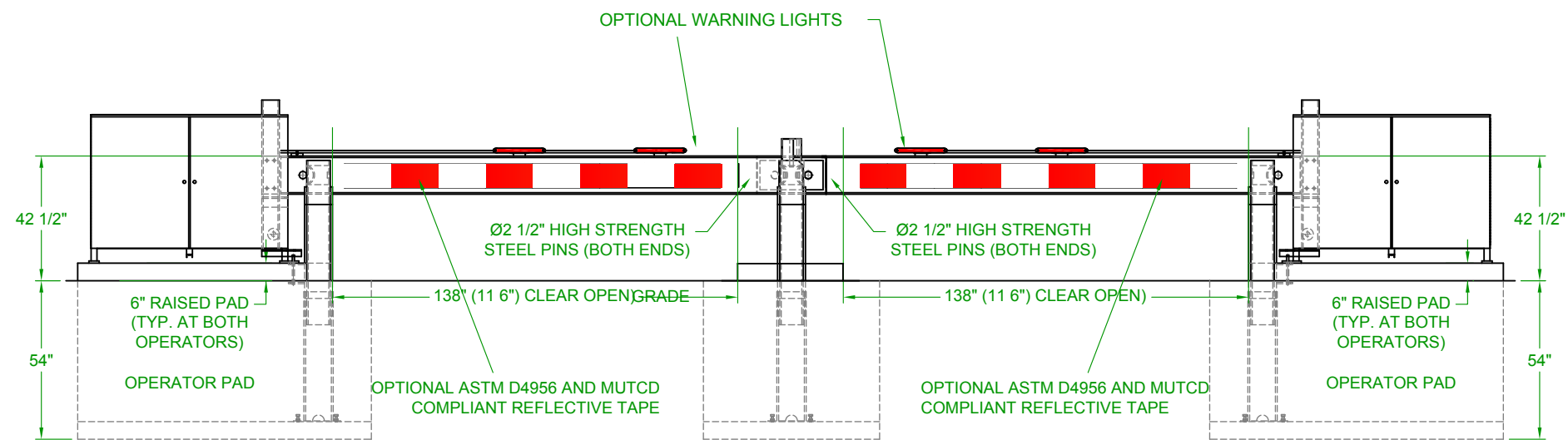

PLAN VIEW

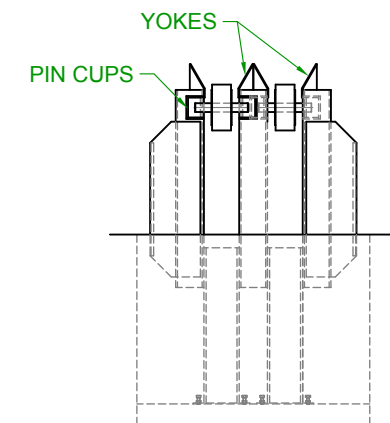

ELEVATION VIEW

* VIEWED FROM THE PRIVATE SIDE *



DO NOT SCALE			NOTICE		Date: 10/09/12	 <p>AG AutoGate Gate Entry Systems Berlin Heights, Ohio FAX (419) 588-3514</p>									
<table border="1"> <thead> <tr> <th>Rev.:</th> <th>Description:</th> <th>Date:</th> </tr> </thead> <tbody> <tr> <td> </td> <td> </td> <td> </td> </tr> <tr> <td> </td> <td> </td> <td> </td> </tr> </tbody> </table>			Rev.:	Description:	Date:								<p>THE INFORMATION CONTAINED ON THIS DOCUMENT IS CONFIDENTIAL. ANY DISSEMINATION, UNAPPROVED DISCLOSURE OR COPYING OF THIS INFORMATION IS STRICTLY PROHIBITED</p>		Drn. By: M.S.
			Rev.:	Description:	Date:										
<p>ANGLES ± 1° X/X ± 1/32, .XX ± .01, .XXX ± .005</p>		<p>DISSEMINATION, UNAPPROVED DISCLOSURE OR COPYING OF THIS INFORMATION IS STRICTLY PROHIBITED</p>		Ckd. By: B.F.	Dwg.:										
		<p>THE INFORMATION CONTAINED ON THIS DOCUMENT IS CONFIDENTIAL. ANY DISSEMINATION, UNAPPROVED DISCLOSURE OR COPYING OF THIS INFORMATION IS STRICTLY PROHIBITED</p>		<p>ANGLES ± 1° X/X ± 1/32, .XX ± .01, .XXX ± .005</p>		Title: K4 Gater VPL Crash Barriers (12' Clear)									